

AVERY DENNISON MARKETING SPECIFICATION

HISTORY			
ENG.	REV.	DATE	DESCRIPTION
DMG	A	9-26-14	RELEASED

THE SUBJECT MATTER DISCLOSED HEREIN EMBODIES PROPRIETARY INFORMATION WHICH IS THE CONFIDENTIAL PROPERTY OF THE AVERY DENNISON CO. NONE OF WHICH SHALL BE COPIED, REPRODUCED, DISCLOSED TO OTHERS, PUBLISHED OR USED IN WHOLE OR IN PART, FOR ANY PURPOSE OTHER THAN THAT FOR WHICH IT IS BEING MADE AVAILABLE WITHOUT THE EXPRESS ADVANCE WRITTEN PERMISSION OF A DULY AUTHORIZED AGENT OF THE COMPANY. THIS DOCUMENT IS THE PROPERTY OF THE AVERY DENNISON CO. AND IS TO BE RETURNED TO THE COMPANY ON DEMAND.

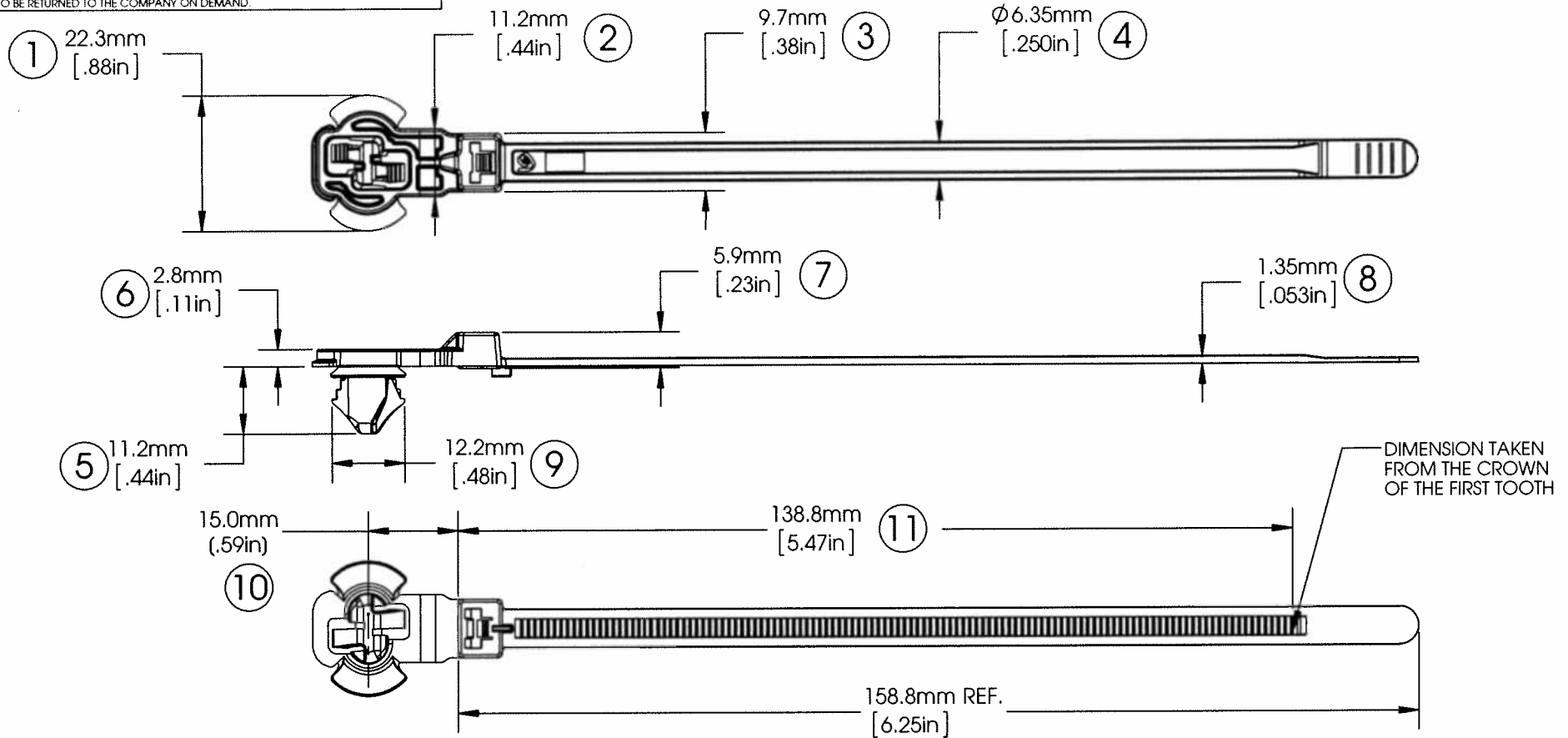

MOUNTING:	7mm X12mm MIN. SLOTTED HOLE
PANEL THICKNESS RANGE:	0.6mm TO 3.0mm THK.
TENSILE STRENGTH:	50 LBF / 222.4N MIN.
OPERATING TEMP RANGE:	-40°F (-40°C) TO 239°F (115°C) CONTINUOUS AND 257°F (125°C) AT MAXIMUM EXPOSURE
WEIGHT:	2.35 GRAMS EACH
BUNDLE DIAMETER:	Ø .06" (1.6mm) TO Ø 1.50" (38.1mm)
INSTALLATION TOOL:	12001 - HAND TOOL 12500 - PNEUMATIC TOOL
TOOL TENSION SETTING:	6 - 8
PACKAGING:	1000/BAG, 5 BAGS/MASTER

APPROVALS:	ENG. APPR. <i>[Signature]</i> 9/26/14
	Q.A. APPR. <i>[Signature]</i> 9/26/14
SPECIFIED TOLERANCES	
INCHES	mm
.XX ± .03	.X ± .7
.XXX ± .010	.XX ± .25
ANGULAR: ± 2°	

AVERY DENNISON <small>FASTENER DIVISION FITCHBURG, MA 01420 U.S.A. TEL. 1-800-225-5913 FAX. 978-353-8157</small>	DESCRIPTION
	OFFSET SLOT TIE, 15mm, STD
STOCK NO.	REV.
20142-0	A